

Dynamic analysis of cracks in composite material

K.Praveen¹, Rakesh Jalla²

¹Department of Mechanical Engineering, CMR Institute of Technology,
Hyderabad, Andhra Pradesh-501401, India.

²Department of Mechanical Engineering, CMR Institute of Technology,
Hyderabad, Andhra Pradesh-501401, India.

Abstract

A crack is a type of fracture that separates a solid body into two or more pieces under the action of stress. There are three types modes of failure, the forces are perpendicular to the crack, the forces are parallel to the crack, the crack is in front back direction, the forces are pulling left and right.

In homogeneous material systems, damage almost always involves cracks. From dynamics and fracture mechanics, it is well known that accelerated crack nucleation and micro crack formation in components can occur due to various reasons, such as transient load swings, higher than expected intermittent loads or defective component materials. Structural systems may be composed of homogeneous and heterogeneous materials such as composites, plastics, ceramics, fabrics and metal - alloys.

The objective of this paper is to investigate how a crack propagates and grows in a clutch. The finite element program ANSYS is used to simulate crack growth and to compute the stresses and the stress-intensity factor. A Geometric model of clutch was designed in 3D by using software Pro/Engineer. Later the geometric model of the clutch converted into FEM model and get analyzed by using ANSYS software to predict the analysis results.

In this present work an attempt has been made to estimate the deflection, stresses under the subjected loads using FEA. The Von Misses stress near the crack tip was compared against the yield strength of the material. The materials of clutch considered are Aluminium alloys 7475, 6061 and composite materials S2 Glass and Kevlar.

Mathematical correlations are calculated determine stress intensity factor, crack extension force, crack opening displacement.

Keywords: Crack Composites, Clutch. ANSYS.

1. Introduction

In homogeneous material systems, damage almost always involves cracks. From dynamics and fracture mechanics, it is well known that accelerated crack

nucleation and micro-crack formation in components can occur due to various reasons, such as transient load swings, higher than expected intermittent loads, or defective component materials. Normal wear causes configuration changes that contribute to dynamic loading conditions that can cause micro-crack formation at material grain boundaries in stress concentrated regions (acute changes in material geometry).

Structural systems may be composed of homogeneous or heterogeneous materials such as composites, plastics, ceramics, fabrics and metal-alloys.

Heterogeneous structures have complicated dynamics of their own in addition to numerous types of damage and failure modes (crack growth, delaminations, fiber breakage, matrix cracking, component failures), which interact in complicated ways that vary tremendously for different initial states, levels of damage accumulation and loading history, making it very difficult to forecast their remaining useful life in operation.

Though there have been abundant, relatively successful efforts to model and predict specific types of failure in complex material and structural systems, this work is directed towards the investigation of a more universal approach 'time-domain' technique can accommodate the diversity of failure modes exhibited by structures.

This work is mainly concerned about time domain plots for various types of damages in composite as well as homogeneous materials.

1.1 Fracture and Damage mechanics

Cracks and flaws occur in many structures and components, sometimes leading to disastrous results. The engineering field of fracture mechanics was established to develop a basic understanding of such crack propagation problems.

Fracture mechanics deals with the study of how a crack or flaw in a structure propagates under applied loads. It involves correlating analytical predictions of crack propagation and failure with experimental results. The analytical predictions are made by calculating fracture

parameters such as stress intensity factors in the crack region, which you can use to estimate crack growth rate. Typically, the crack length increases with each application of some cyclic load, such as cabin pressurization-depressurization in an airplane. Further, environmental conditions such as temperature or extensive exposure to irradiation can affect the fracture propensity of a given material

1.2 Cracks

A crack is a type of fracture that separates a solid body into two, or more, pieces under the action of stress. There are three types of modes of failure.

Mode I: The forces are perpendicular to the crack (the crack is horizontal and the forces are vertical), pulling the crack open. This is referred to as the opening mode.

Mode II: The forces are parallel to the crack. One force is pushing the top half of the crack back and the other is pulling the bottom half of the crack forward, both along the same line. This creates a shear crack. The crack is sliding along itself. It is called in-plane shear because the forces are not causing the material to move out of its original plane.

Mode III: The forces are perpendicular to the crack (the crack is in front-back direction, the forces are pulling left and right). This causes the material to separate and slide along itself, moving out of its original plane (which is why it's called out-of-plane shear).

1.3 Defects in Clutches

The most common problem with clutches is that the friction material on the disc wears out. The friction material on a clutch disc is very similar to the friction material on the pads of a disc brake or the shoes of a drum brake after a while, it wears away. When most or all of the friction material is gone, the clutch will start to slip, and eventually it won't transmit any power from the engine to the wheels.

The clutch only wears while the clutch disc and the flywheel are spinning at different speeds. When they are locked together, the friction material is held tightly against the flywheel, and they spin in sync. It's only when the clutch disc is slipping against the flywheel that wearing occurs. So, if you are the type of driver who slips the clutch a lot, you'll wear out your clutch a lot faster.

Sometimes the problem is not with slipping, but with sticking. If your clutch won't release properly, it will continue to turn the input shaft. This can cause grinding, or completely prevent your car from going into gear. Some common reasons a clutch may stick are:

Broken or stretched clutch cable - The cable needs the right amount of tension to push and pull effectively.

Leaky or defective slave and/or master clutch cylinders - Leaks keep the cylinders from building the necessary amount of pressure.

Air in the hydraulic line - Air affects the hydraulics by taking up space the fluid needs to build pressure.

Misadjusted linkage - When your foot hits the pedal, the linkage transmits the wrong amount of force.

Mismatched clutch components - Not all aftermarket parts work with your clutch.

A "hard" clutch is also a common problem. All clutches require some amount of force to depress fully. If you have to press hard on the pedal, there may be something wrong. Sticking or binding in the pedal linkage, cable, cross shaft, or pivot ball are common causes. Sometimes a blockage or worn seals in the hydraulic system can also cause a hard clutch.

Another problem associated with clutches is a worn throw-out bearing, sometimes called a "**clutch release bearing**". This bearing applies force to the fingers of the spinning pressure plate to release the clutch. If you hear a rumbling sound when the clutch engages, you might have a problem with the throw-out.

2. Methodology and Design of Clutch

The focus of this paper is to investigate how a crack propagates and grows in a clutch. The finite element program ANSYS is used to simulate crack growth and to compute the stresses and the stress-intensity factor. A specific clutch is designed and a crack is investigated. The Von Mises stress near the crack tip is compared against the yield strength of the material. The Mode I stress-intensity factor is compared against the material's fracture toughness.

The analysis is done on the clutch before crack and propagated crack after load steps. The materials for clutch considered are Aluminum Alloys 7475 and 6061, Composite materials S2 Glass and Kevlar.

The methodology followed as given below

CAD model creation:-The geometric model of clutch was designed as per design specifications by using pro-e software

Stress analysis of the un cracked body In this step geometric model converted into FEM model and get analyzed in ANSYS to predict the analysis results.

Flaw implementation In this step crack was introduced in the design part of clutch for crack analysis purpose.

Elastic stress analysis of the cracked bodyIn this analysis processes the crack was analyzed under subjected loads by using ANSYS.

Calculation of stress intensity factorIn this analysis part stress intensity factor found in both ANSYS and theoretical.

Interpretation of results The results found from both ANSYS and theoretical were compared.

Using Pro-e software clutch parts are designed

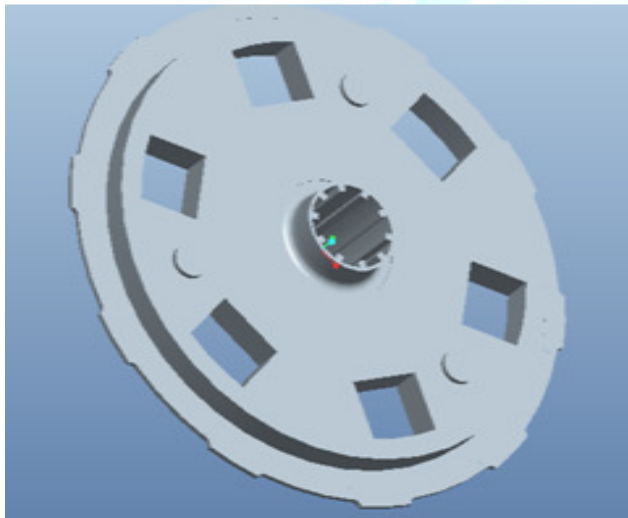

Fig.1 Pressure Plate

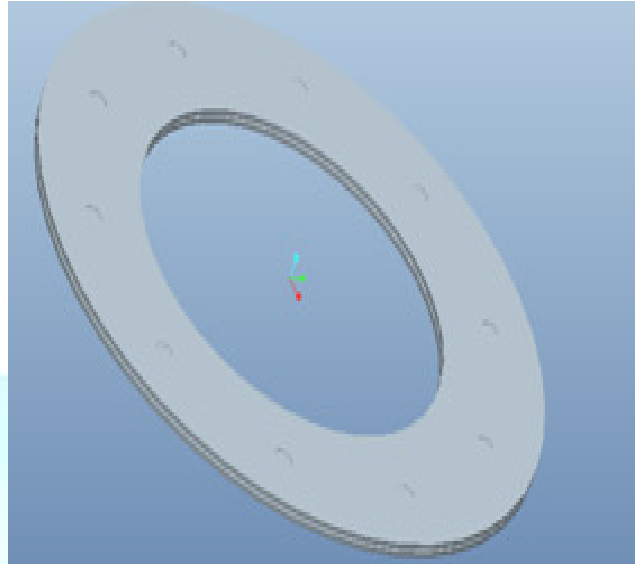

Fig 2 Clutch Plate

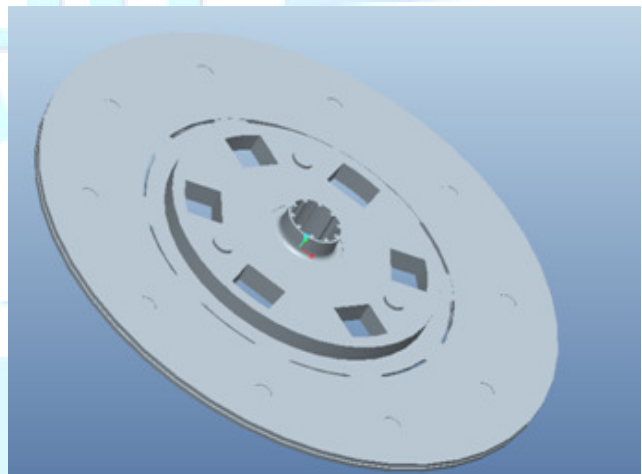
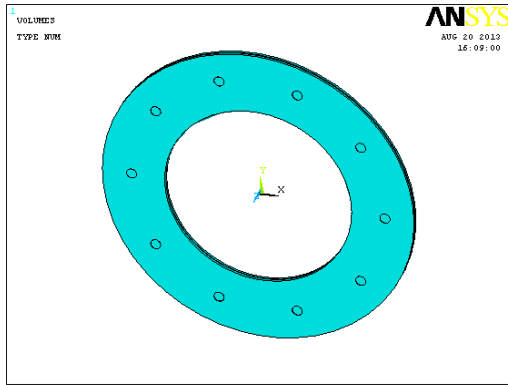

Fig 3. Assembly

3 Finite Element Analysis

Structural and dynamic analysis was done for pressure plate and clutch plate with crack and without crack by taking Aluminum Alloys 7475 and 6061, Composite materials S2 Glass and Kevlar .



(a)

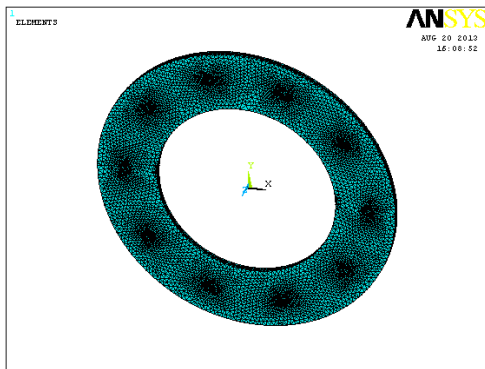

(b)

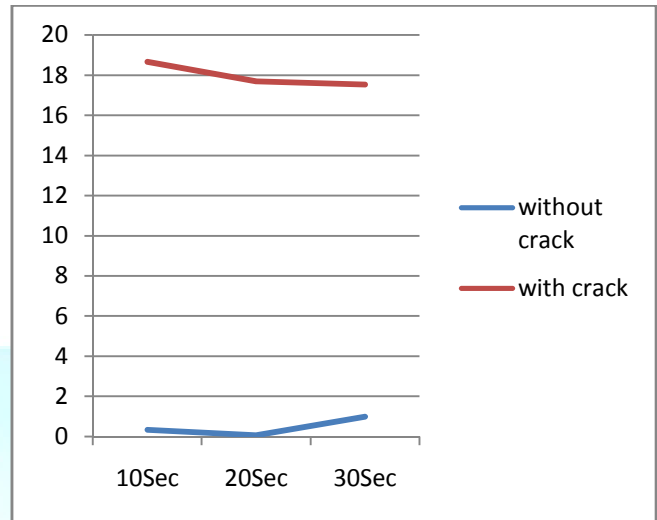

(a)

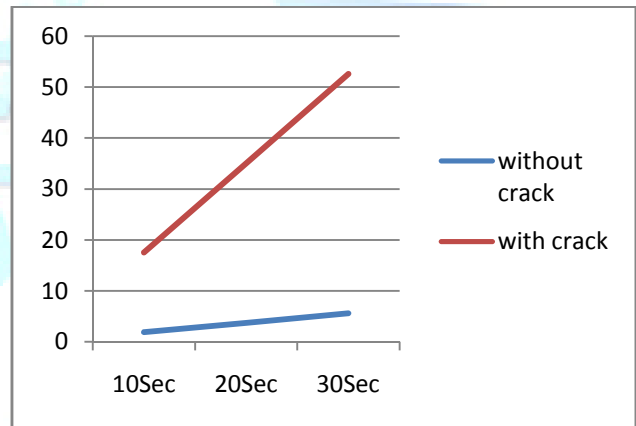

(b)

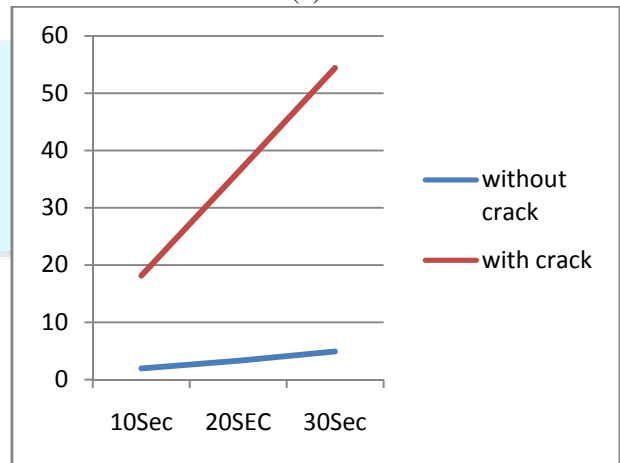

(c)

Fig 4(a) Clutch plate model (b) Meshing of pressure plate (c) Nodal solutions of clutch plate

4 Results

Static and Dynamic analyses are done in finite element analysis software Ansys. The analysis is done on the clutch before crack and propagated crack after load steps.

By observing the analysis results, the stress values are more for composite materials and when the crack is started the composite materials, stress values increases more than the condition of no crack so the composite materials fails faster once the crack propagates.

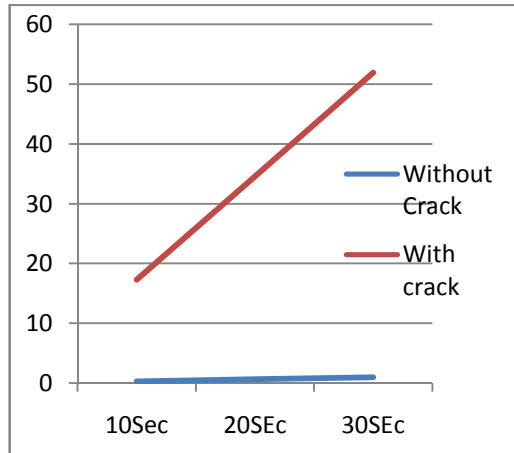

(d)

Fig 6 Graphical representation of stress values of dynamic analysis – without crack and with crack (a) aluminum 7475 (b) aluminum 6061 (c) s2 glass (d) kevlar

3. Deformation and Fracture Mechanics of Engineering Materials by Richard W. Hertzberg, Richard P. Vinci and Jason L. Hertzberg
4. Failure Analysis of Engineering Materials by Charles Brooks, Ashok Choudhury and Charlie R. Brooks
5. Failure of Materials in Mechanical Design: Analysis, Prediction, Prevention, 2nd Edition by Jack A. Collins
6. Principles of Fracture Mechanics by R. J. Sanford
7. Fracture Mechanics by Chin-Teh Sun and Zhihe Jin Department Of Mechanical Engineering University of Maine
8. Fracture Mechanics and Crack Growth by Naman Recho
9. Application of Fracture Mechanics to Polymers, Adhesives and Composites by D R Moore
10. Fracture of Polymers, Composites and Adhesives II by J G Williams, A Pavan, Bamb

5. Conclusions

In this Paper, a clutch plate is analyzed for crack propagation for different materials Aluminium alloy 6061, Aluminium alloy 7475, Composite materials S2 Glass and Kevlar. Theoretical calculations are done to determine stress intensity factor, crack extension force, crack opening displacement.

By observing the theoretical calculations, the stress intensity factor and crack opening displacement are more for composite materials.

Static and Dynamic analyses are done in finite element analysis software Ansys. The analysis is done on the clutch before crack and propagated crack after load steps.

By observing the analysis results, the stress values are more for composite materials and when the crack is started the composite materials, stress values increases more than the condition of no crack so the composite materials fails faster once the crack propagates.

So we can conclude that if the crack propagates in the composite materials, they tend to fail faster than aluminium alloys thereby reducing their life. So care should be taken for composite materials not to get the crack.

6 References

1. Machine Design by R.S. Khurmi
2. Mechanical Metallurgy by George E. Dieter